

The size 23 hybrid precision linear actuator is with high performance and longer working cycle, which could be applied with high request of force, it is capable of 910N.

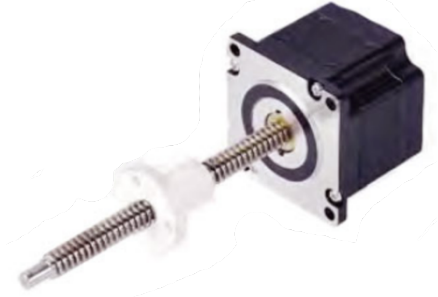

- **Motor characteristics**

Motor	Voltage (v)	Current (A)	Resistance ( $\Omega$ )	Inductance (mH)	Weight (g)	Lead wire no.	Motor length (mm)
ACT2345-10-E150	6,4	1,0	6,4	16,4	585	4	45
ACT2345-20-E150	3,2	2,0	1,75	4,1	585	4	45
ACT2345-30-E150	2,1	3,0	0,8	1,7	585	4	45
ACT2365-10-E150	10,8	1,0	11,5	32,0	880	4	65
ACT2365-25-E150	4,2	2,5	2,0	5,2	880	4	65
ACT2365-40-E150	2,4	4,0	0,7	2,0	880	4	65

- **Available lead screw and travel per step**

Screw Dia. (inch)	Screw Dia. (mm)	Lead (inch)	Lead (mm)	Lead Code	Travel Per Step @ 1.8 deg (mm)	Travel Per Step @ 0,9 deg (mm)
0,315	10,000	0,079	2,0000	MG	0,0100	0,0050
0,315	8,000	0,158	4,0000	MM	0,0200	0,0100
0,315	8,000	0,315	8,0000	MT	0,0400	0,0200
0,375	9,525	0,025	0,6350	A	0,0030	0,0016
0,375	9,525	0,050	1,2700	D	0,0060	0,0032
0,375	9,525	0,062	1,5875	F	0,0080	0,0040
0,375	9,525	0,083	2,1167	H	0,0110	0,0053
0,375	9,525	0,100	2,5400	K	0,0120	0,0064
0,375	9,525	0,125	3,1750	L	0,0150	0,0079
0,375	9,525	0,167	4,2333	P	0,0210	0,0106
0,375	9,525	0,200	5,0800	R	0,0250	0,0127
0,375	9,525	0,250	6,3500	S	0,0310	0,0159
0,375	9,525	0,375	9,5250	V	0,0470	0,0238
0,375	9,525	0,384	9,7536	W	0,0480	0,0244
0,375	9,525	0,400	10,1600	X	0,0510	0,0254
0,375	9,525	0,500	12,7000	Y	0,0630	0,0318
0,375	9,525	1,000	25,400	Z	0,1270	0,0635

- Dimensional Drawings (External Actuator)

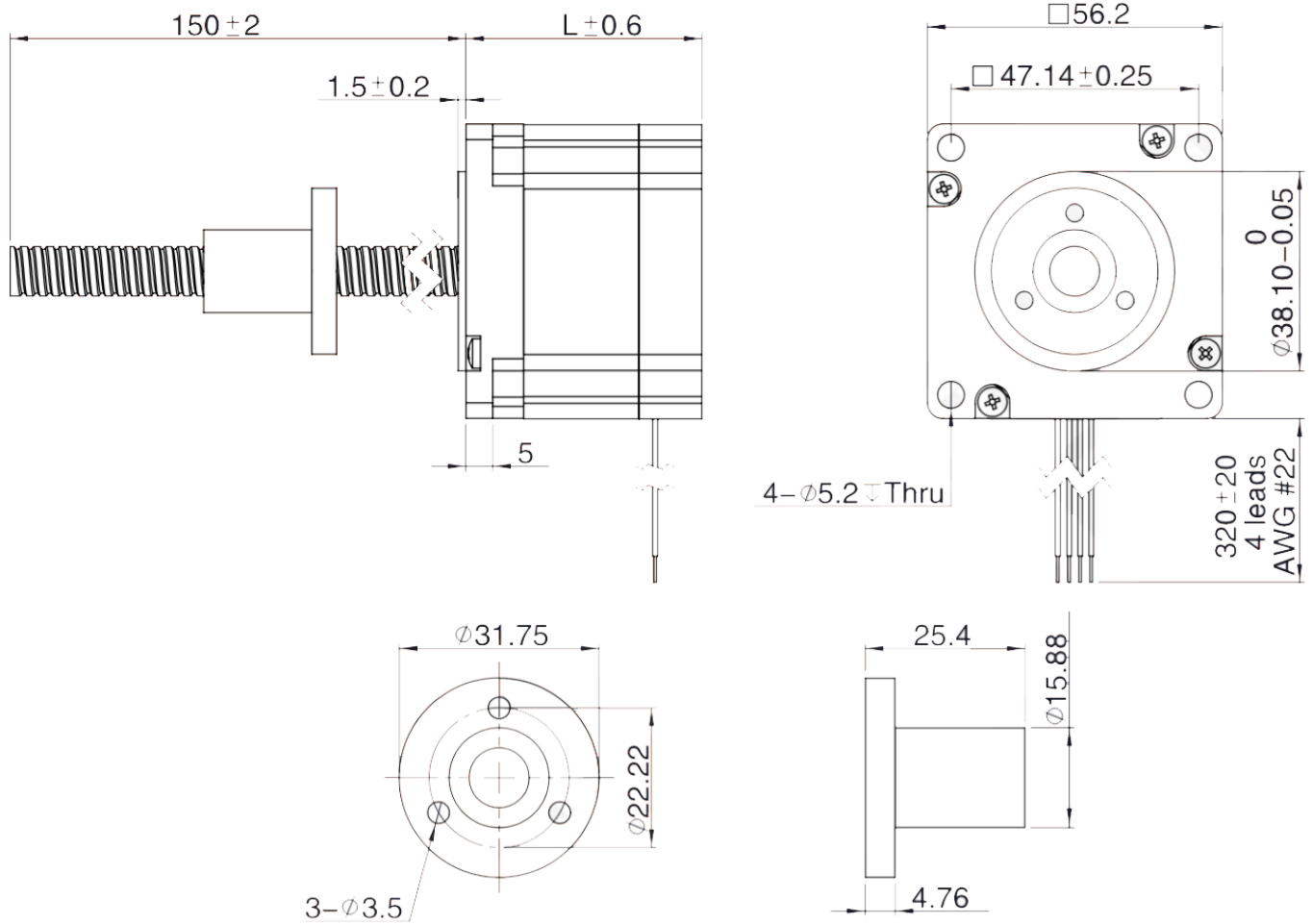

## • Size 23 (57mm) Performance curves

### Single stack speed thrust curves

Bipolar, Chopper driver 2,0 A RMS

Screw diameter 9,525 mm, Recommended load limit 910N

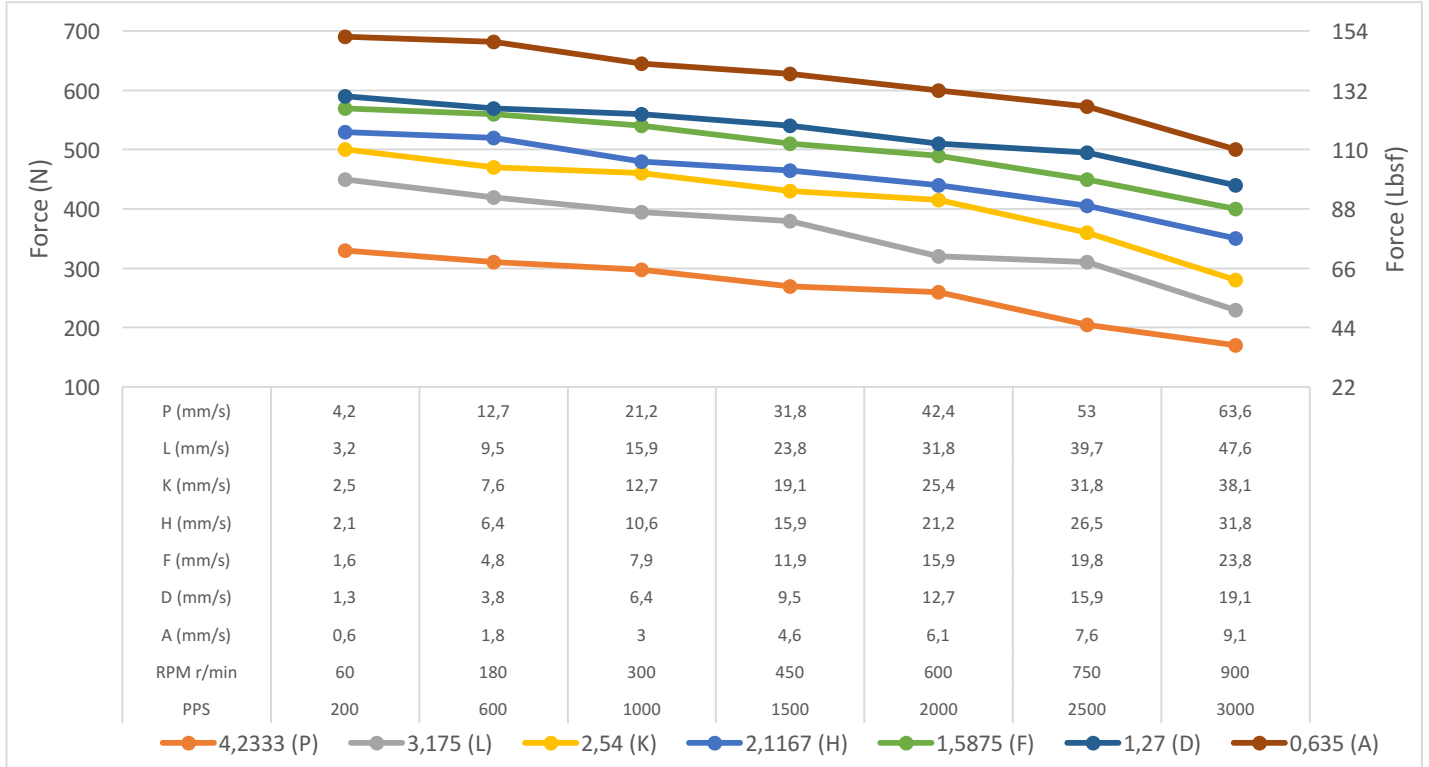

### Single stack speed thrust curves

Bipolar, Chopper driver 2,0 A RMS

Screw diameter 9,525 mm, Recommended load limit 910N

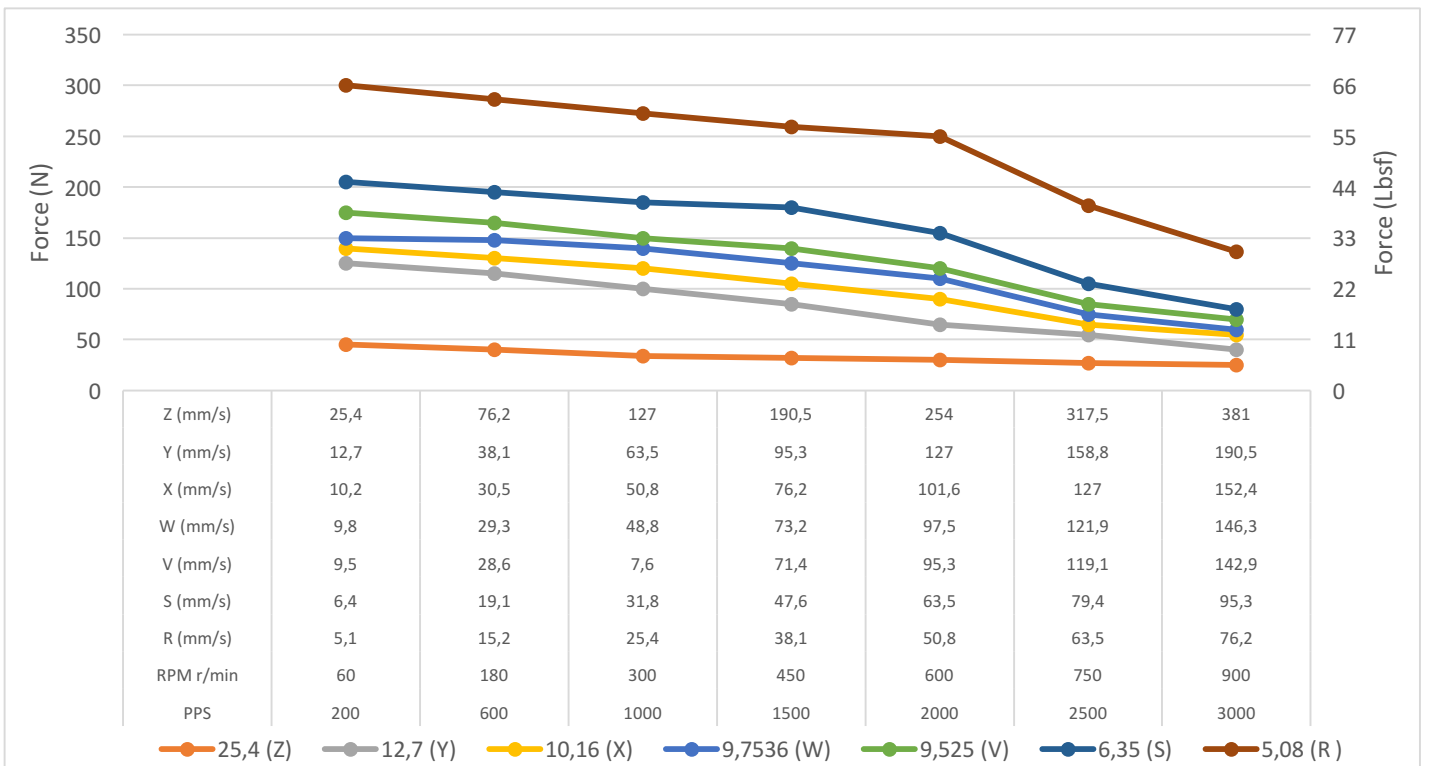

## Double stack speed thrust curves

Bipolar, Chopper driver 4,0 A RMS

Screw diameter 9,525 mm, Recommended load limit 910N

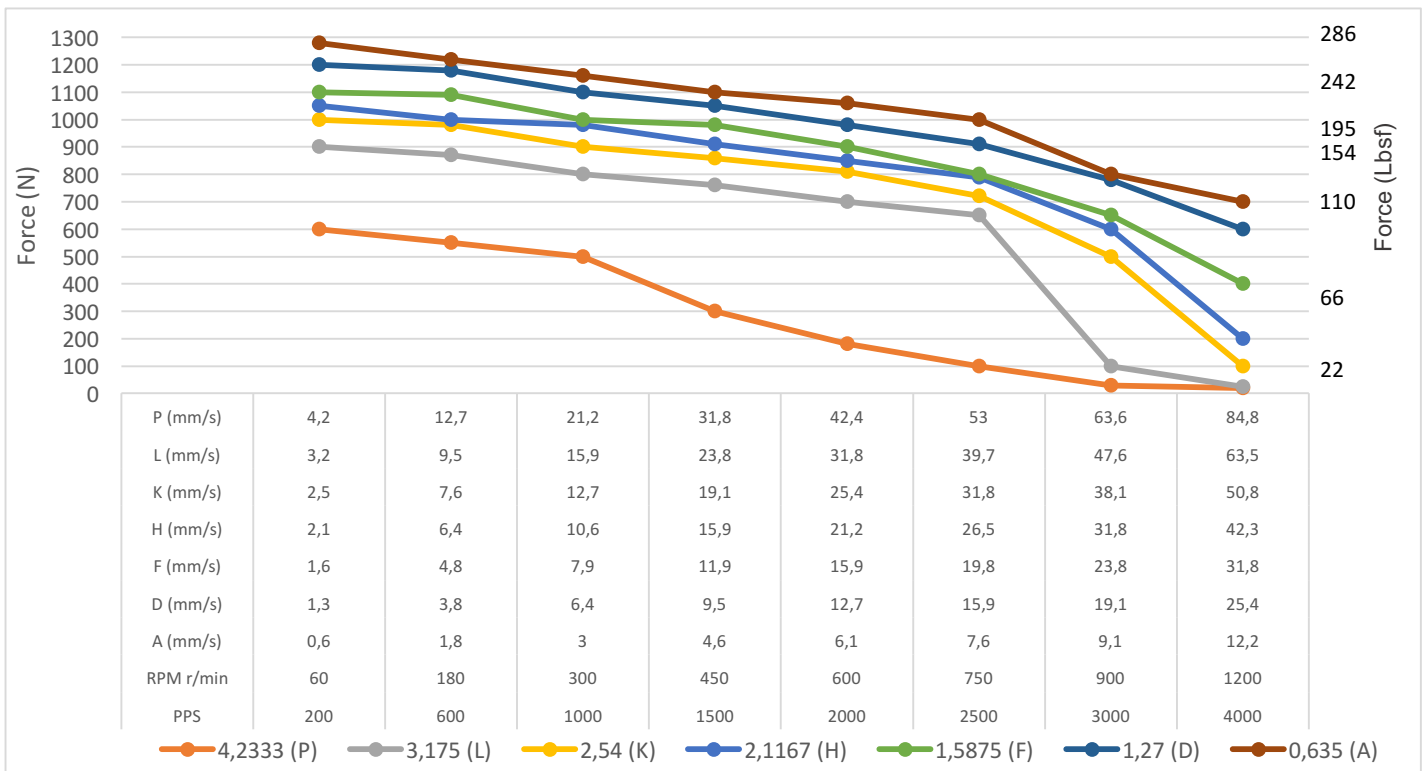

## Double stack speed thrust curves

Bipolar, Chopper driver 4,0 A RMS

Screw diameter 9,525 mm, Recommended load limit 910N

