

User manual EZD-1136

Order command : EZD-1136-CANOPEN

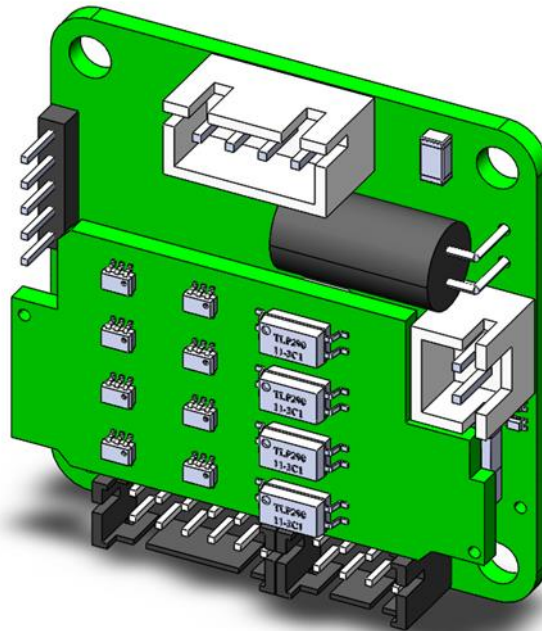

Revisions

Version	Modifications	Writer	Checker	Date
1.0	Initial version	MLE	SRU	06/11/2024
1.1	Add electric information	MLE	SRU	25/11/2024
1.2	Add Preface and electric information	MLE	SRU	03/01/2025
1.3	Patch	MLE	SRU	23/01/2025
1.4	Modification in dimension part	MLE	SRU	06/02/2025

Table of Contents

1.	<i>Preface</i>	3
•	Product Quality Guarantee	3
•	Usage Precautions.....	3
•	Safety Precautions	4
2.	<i>Product overview</i>	6
•	Introduction	6
•	Functional Features.....	7
•	Technical Parameters.....	8
3.	<i>PIN OUT</i>	9
•	J1: Power 24V.....	9
•	J2 : Motor phases.....	9
•	J3: RS232 TTL.....	10
•	J6: CAN et Analog IN	11
•	J7: GPIO	12
4.	<i>Ectrical specifications</i>	13
•	Motor Connection.....	13
▪	Motor Connection Method	13
▪	Motor Connection	14
•	Input Power.....	15
▪	Input Voltage.....	15
▪	Current	15
▪	No-Load Current.....	15
▪	Regenerative Current	15
•	Input Port	16
▪	Sourcing or sink digital input	16
▪	Analog input	17
•	High-speed Input Port.....	17
▪	Pulse Signal: PULSE.....	17
▪	Direction Signal: DIR	17
▪	Pulse/Direction Input Timing Diagram	18
•	Output Port	19
▪	Sourcing or Sinkink digital output.....	19
•	Wiring Requirements	20
5.	<i>Dimensions</i>	21
6.	<i>Supplemental directives</i>	22
•	Copyright.....	22
•	Trademark Designations and Symbols	22
•	Target user	22
•	Disclaimer: Life Support Systems	22
•	Disclaimer: Intended Use	23

1. Preface

• Product Quality Guarantee





- If the product experiences quality issues within one year of purchase (excluding issues caused by improper operation or failure to meet specified conditions), it can be returned to us for processing after confirmation by our company.
- If the failure is due to improper operation or non-compliance with the specified usage conditions, or if the failure occurs after one year of purchase, a repair fee may be charged. If the product is used in critical applications, we strongly recommend purchasing additional spare units to ensure system continuity and stability.
- When sending a defective product for repair, please ensure that the product is properly packaged. We are not responsible for any damage caused during transportation.
- Repairs typically require several working days, and we appreciate your understanding.
- The following situations are not covered under the product warranty:
 - A) Failures caused by usage that does not comply with the instructions, conditions, environment, or operations specified in the product manual.
 - B) Failures resulting from modifications, repairs, or disassembly performed by parties other than our company.
 - C) Failures caused by usage methods not specified by the company.
 - D) Failures caused by reasons that could not have been reasonably predicted based on the scientific and technical standards at the time of shipment.
 - E) Failures caused by force majeure events (such as natural disasters, wars, etc.).

• Usage Precautions

- Please adhere to the rated values and conditions specified in this manual when using the product.
- The design and manufacturing purpose of our products is not for use in life-critical applications or environments. If the product is to be used for special purposes, please inform our sales staff for discussion and confirmation.
- Our company is committed to continuously improving product quality and customer trust. However, when using our products, please ensure the design includes multiple backup systems, fire safety measures, fail-safe mechanisms, etc., to prevent accidents such as personal injury, fires, or other societal damages due to system failure.
- To continuously improve performance, product specifications may be changed or upgraded without prior notice.

• Safety Precautions

To ensure the safety of all users, the following table lists safety precautions to be observed when using this drive board. The precautions are described in detail.

 Danger	Indicates that a failure could lead to hazardous situations, with the possibility of death or severe injury.
 Attention	Indicates that a failure could lead to hazardous situations, with the possibility of moderate personal injury or minor injury, and potentially material damage.
 Prohibition	Indicates that it shall not be violated
 Enforcement	Indicates that it must be completed

 Danger	
<ul style="list-style-type: none"> ● Do not touch the terminal section and its interior with your hands while it is energized. Otherwise, there is a danger of electric shock. ● Do not pull or twist the cable, or place heavy objects on the cable. Otherwise, there is a danger of electric shock and fire. ● Do not touch any of the rotating parts while the motor is running. Otherwise there is a risk of being caught in the rotor shaft and causing injury. ● Do not touch the inside of the driver board with your hands under power-up condition. Otherwise there is a danger of electric shock. ● Do not touch the terminals within 5 minutes of the power being turned off. Otherwise there is a danger of electric shock. ● Be sure to ground the ground terminals of the driver board and motor. Otherwise there is a risk of electric shock. ● Movements, wiring, maintenance, inspection, etc. should be performed after confirming that the power is off and the display light on the panel is completely off. Otherwise, there is a danger of electric shock. 	

 Attention	
<ul style="list-style-type: none"> ● Do not use this product in places where water, oil, or pharmaceutical droplets may be contaminated, or where corrosive or flammable gases are present. ● Please strictly observe the requirements in the product manual. Otherwise there is a risk of damage to the product or injury to persons. ● The temperature of the driver board, motor, and the surrounding machine itself will rise so please do not touch it. Otherwise there is a risk of burns. ● Use the motor and driver board in the specified combination. Otherwise, there is a risk of fire. ● The heat sink and motor of the driver board may still be in a high temperature state when the power is turned on or shortly after the power is turned off, so do not touch them. Otherwise, there is a risk of burns. ● Do not apply excessive pressure to the edge areas of the housing. Otherwise there is a risk of deformation. ● Ensure that the driver board is installed in a well-ventilated area that is easy to maintain and inspect. ● If the ambient temperature of the driver board is higher than 40°C , please check the exhaust or ventilation equipment and request forced air cooling. 	

 **Prohibition**

- Do not use or store the product in places exposed to direct sunlight.
- Do not use the product in places where the ambient temperature and humidity exceed the specified range, or store the product.
- Do not use this product in places where there is a lot of dust, dirt, etc., or store it.
- Do not use or store this product in locations subject to direct vibration or shock.
- Do not use this product in direct sunlight or near magnetic, radioactive or radioactive objects, or store it.
- Do not repair or modify the internal or external structure of this product by yourself.
- Do not install mechanical equipment with high heat generation and electromagnetic interference around the driver board.

 **Enforcement**

- Before starting operation, check that the emergency switch can be activated at any time to stop the machine.
- Maintain at least the following mounting spacing between the driver boards and with other equipment. Ensure adequate mounting spacing as much as possible, otherwise the usability and life of the driver board will be damaged.

2. Product overview

• Introduction

EZYDRV-1136 is a magnetic encoder closed-loop stepper drive board for CAN communication.

The input voltage range of the motor drive is DC 18-30V, and the maximum output current is 3.0A peak, Inputs and output are available. Communication is CAN communication or pulse and direction, with reserved RS485 communication extension.

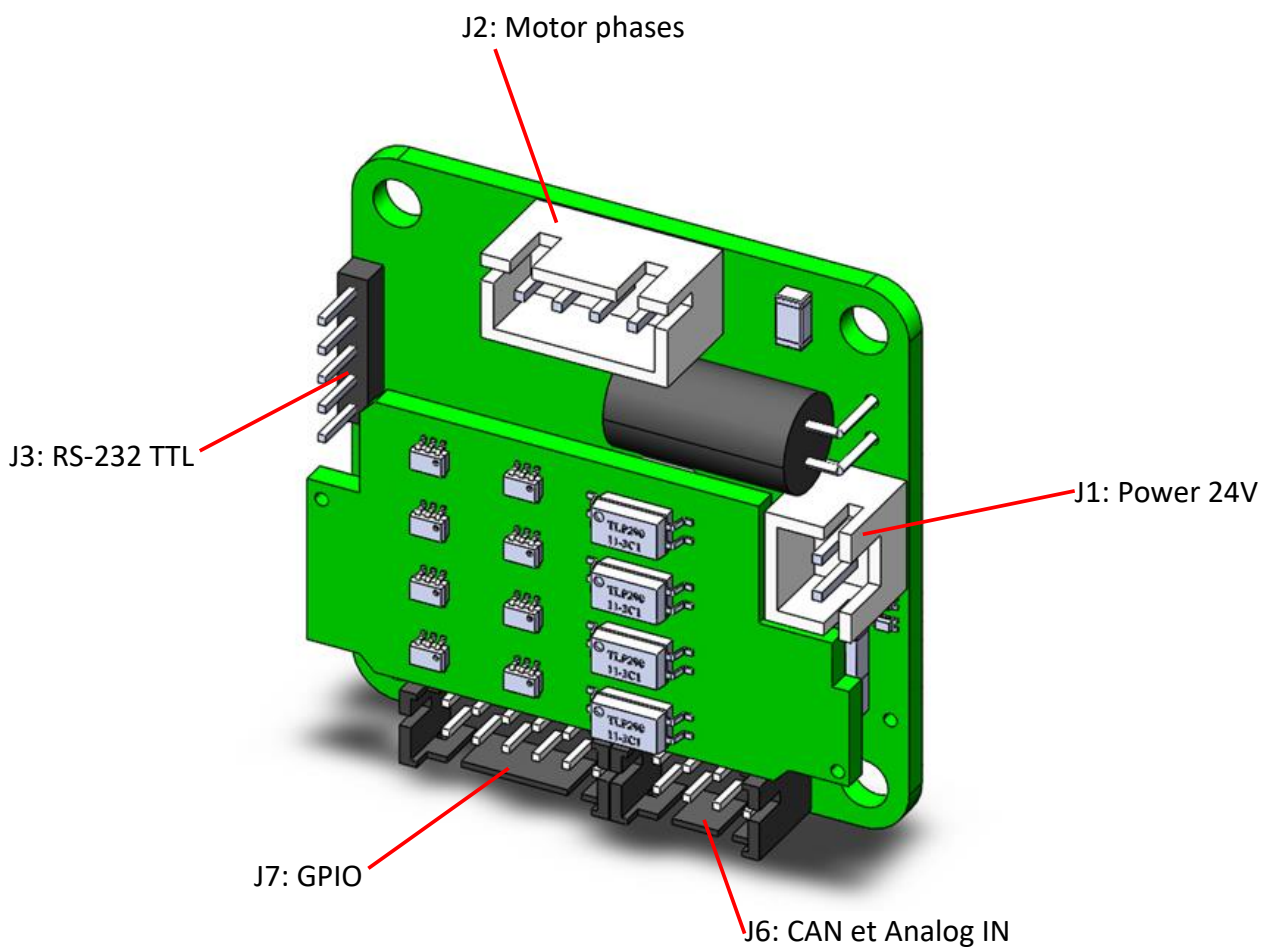

• Functional Features

- Input power: DC 20 ~ 30V
- Supports magnetic encoder closed-loop motors with a maximum peak current of 3.0A.
- 2 high-speed inputs (configurable as pulse signals and direction signals), 4 general-purpose digital signal inputs.
- 2 configurable digital outputs.
- 1 analog input (0~10V).
- CAN communication interface, supports CANOPEN protocol, and can support up to 32 stations.
- RS485 communication interface, supports MODBUS/RTU protocol, and can support up to 32 stations.
- Closed-loop control methods: supports pulse/direction mode, communication control mode, and built-in Program IO trigger mode.
- Control signals: enable the drive board, start/stop, emergency stop, limit switch, and other functions.
- Stable and precise current control, with low motor heating.
- Motor protection functions: short circuit protection, overcurrent protection, overvoltage protection, undervoltage protection, etc.

• Technical Parameters

Item		Content	
Adapted motor		Two-phase hybrid magnetic encoding stepper motor	
Output current (peak)		0.3A ~ 3.0A/ phase	
Overvoltage protection		32VDC	
Undervoltage protection		18VDC	
Digital input / output interface	Input	2 way high-speed signal inputs	Can be configured as pulse / direction signal
		4 digital inputs	Optocoupler input voltage 4 ~ 24V Conduction current 5 ~ 8mA
	Output	2 digital outputs	Photoelectric isolated output with a maximum voltage of 30VDC and a maximum saturation current of 50mA
Digital input details		Servo On	
		RESET	
		RUN/STOP	
		JOG	
		HOME	
Digital output details		IN POSITION	
		ALARM	
Analog input		0 ~ 10 VDC	
LED indication		Status, Fault	
Communication I/F		RS485 (TTL)	
		CAN	
Control method		Position control mode	
		Torque control mode	
Size		37 × 37 × 12.05 mm	
Weight		About 200g	
Environmental Specifications	Surrounding Air Conditions	Avoid dust, oil mist and corrosive gases, and avoid installation in direct sunlight or near magnetic, radioactive or radioactive objects.	
	Humidity	<85%RH, no condensation	
	Operating temperature	°C	
	Storage temperature	-10-70 °C	
	Heat dissipation	Install in a ventilated environment	

3. PIN OUT

• J1: Power 24V

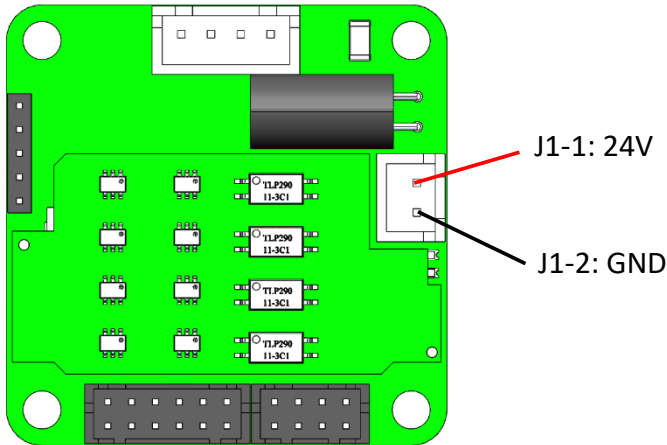

J1	Function
J1-1	V+
J1-2	V-

Counterparts : JST XHP-2

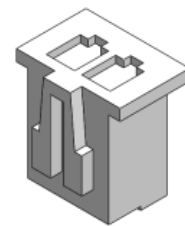

Range voltage between 20 and 30 Volt. Nominal voltage : 24 Volt

Note : Please ensure correct wiring and pay attention to the power polarity. Ensure no short circuit occurs to prevent damage to the host computer and the driver board

• J2 : Motor phases

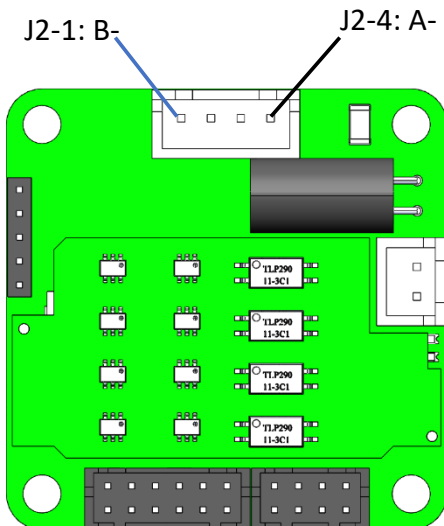

J2	Function
J2-1	B-
J2-2	B+
J2-3	A+
J2-4	A-

Counterparts : JST XHP-4

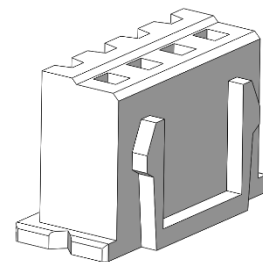

● **J3: RS232 TTL**

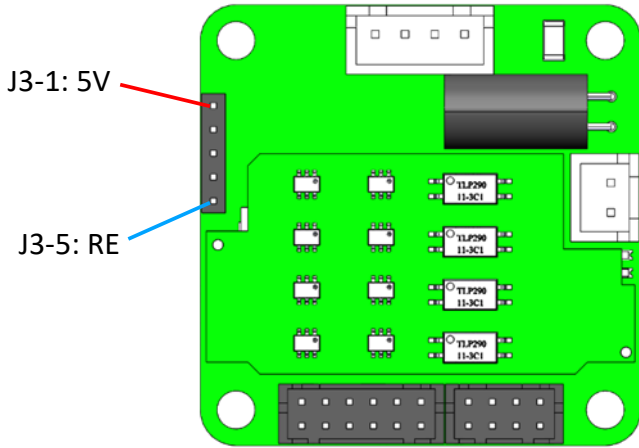

J3	Function
J3-1	+5V
J3-2	0V
J3-3	TXD
J3-4	RXD
J3-5	RE

Counterparts : JST PHR-5

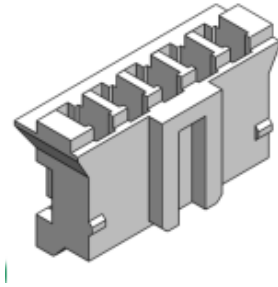

Note : RS485 communication extension interface, TTL output. Please ensure correct wiring and pay attention to power polarity.

In order to connect the EZD-1136 to your computer, to set up and program the driver, two adapters are required.

They can be buy at A2V, the name is : **EZD-1136-PRG**

The first one adapter is use to convert RS282-TTL to RS485.

The second adapter is use to convert RS485 to USB.



• J6: CAN et Analog IN

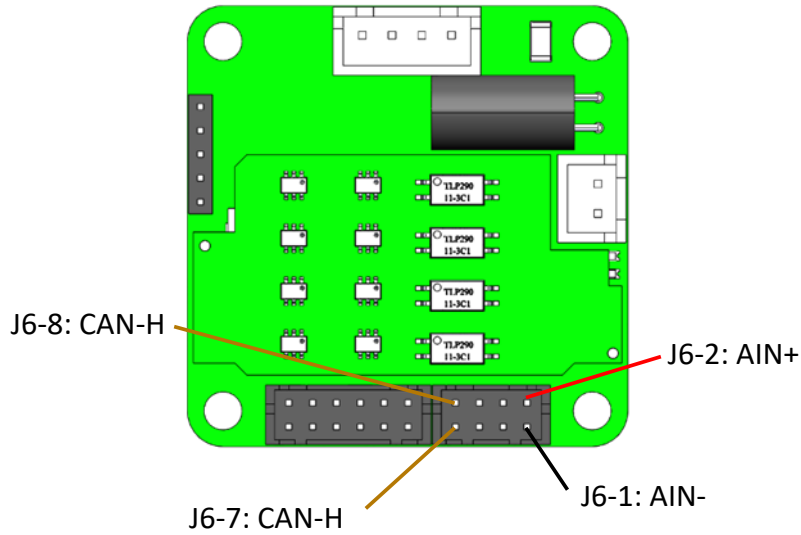

→ x1 channel analog input: AIN1 input (0-10V)

J6	Function
J6-1	AIN-
J6-2	AIN+
J6-3	NC(*)
J6-4	NC
J6-5	CANL
J6-6	CANL
J6-7	CANH
J6-8	CANH

(*:NC means not – connected)
Counterparts : JST PHDR-08VS

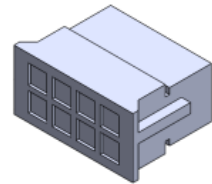

• **J7: GPIO**

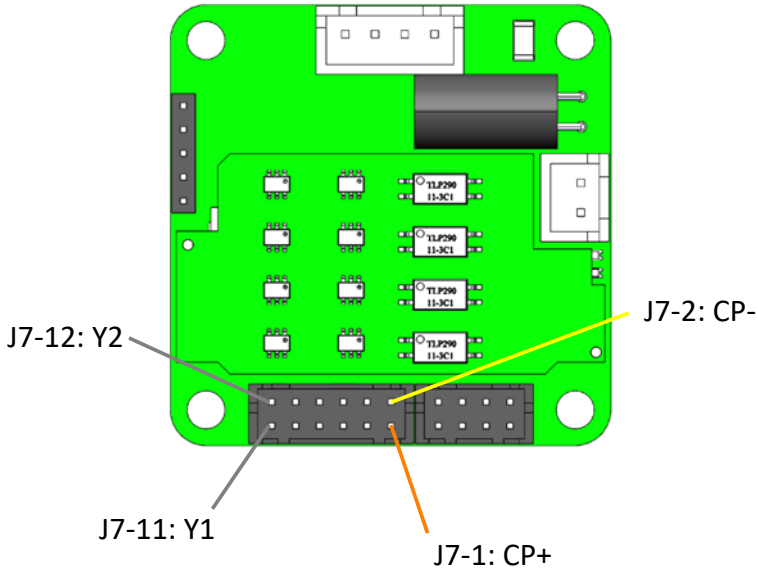

J7	Function
J7-1	CP+
J7-2	CP-
J7-3	DR+
J7-4	DR-
J7-5	X1
J7-6	X2
J7-7	X3
J7-8	X4
J7-9	IN_COM
J7-10	OUT_COM
J7-11	Y1
J7-12	Y2

Counterparts: JST PHDR-12VS

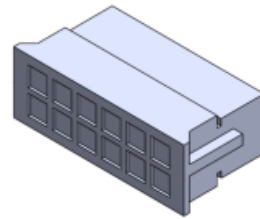

4. Electrical specifications

• Motor Connection

***WARNING:** When connecting the motor to the driver board, first make sure that the driver board power is turned off. Verify that unused motor leads are not shorted to other objects. The motor cannot be disconnected while the driver board is energized.

- Motor Connection Method

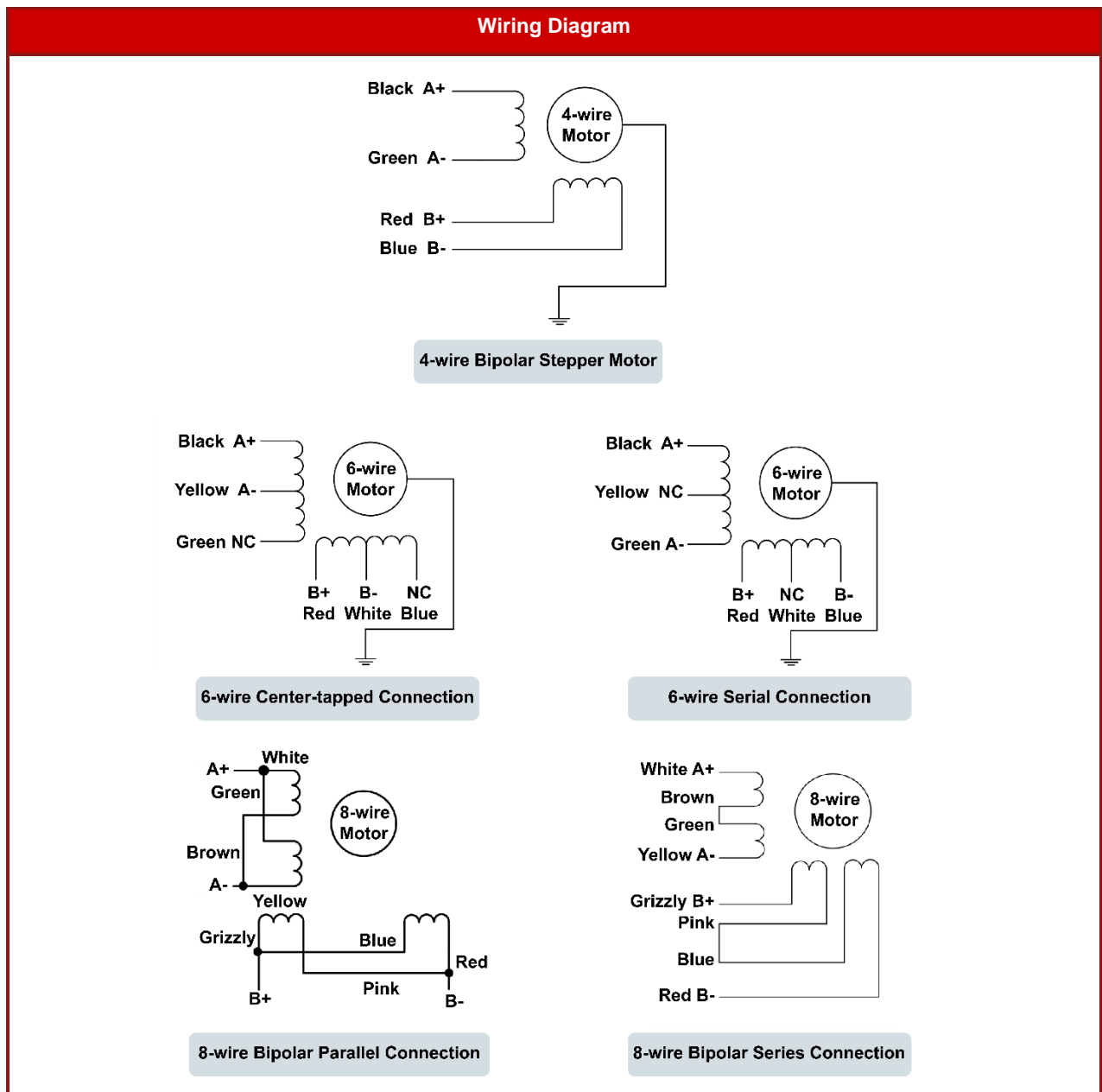

▪ Motor Connection

- Four-wire motors can only be connected in one way.
- Six-wire motors can be connected in two ways: full group and half group. In full group mode, the motor has more torque running at low speeds, but cannot run as fast as if it were connected to a half group. When running in full group, the motor needs to run at 30% less current than in half group mode to avoid overheating.
- Eight-wire motors can be connected in two ways: series and parallel. Series connection has more torque at low speeds and less torque at high speeds. When running in series, the motor needs to run at 50% of the parallel current to avoid overheating.
- The phases are relative, but the windings of different phases can not be connected to the terminals of the same phase of the driver board (A+, A- for one phase, B+, B- for the other phase), if the motor steering is different from the desired steering at the same time, only exchange the position of A+, A- can be.
- Judge the stepping motor series or parallel connection method is correct or not: in the conditions without access to the driver board by hand to directly rotate the motor's shaft, if you can easily and evenly rotate is shown to be wired correctly, if encountered resistance and uneven and accompanied by a certain amount of sound is shown to be wired incorrectly.
- **This driver board can only drive two-phase hybrid stepper motors, not three-phase and five-phase stepper motors.**
- **The wiring colors in the above motor connections are common and are for reference only, please refer to the motor specification manual for specific wiring.**

• Input Power

▪ Input Voltage

The maximum working voltage range for the driver board is 18 ~ 30V DC, with a recommended supply voltage of 20 ~ 30V DC.

A voltage stabilizing capacitor can absorb current spikes on the power line, preventing the driver board from falsely triggering a protection fault.

When operating the driver board at low voltage, it is recommended to parallel a larger stabilizing capacitor at the power input to prevent low voltage alarms caused by unstable power supply.

The driver board is not recommended for use when the supply voltage is below 18V, as it may result in unreliable operation.

When the driver board uses a regulated power supply and the supply voltage approaches 32V, it is recommended to implement voltage clamping measures at the power input to prevent the supply voltage from exceeding 32V, which could trigger an over-voltage alarm and stop the driver board.

When using an unregulated power supply, ensure that the no-load output voltage does not exceed 22V DC, as the rated current of unregulated power supplies is the maximum load current. When the load is lighter, such as when the motor is not running, the actual voltage can reach up to 1.4 times the rated voltage. For smoother and quieter motor operation, it is recommended to use a lower voltage.

▪ Current

The maximum supply current should be the sum of the current from both phases. In general, the required current depends on the motor type, voltage, speed, and load conditions. The actual power supply current is usually much lower than this maximum value because the driver board uses a switching amplifier to convert a high voltage, low current signal into a low voltage, high current signal through a power switch. The rated voltage of the motor windings is often very low, and the higher the supply voltage to the driver board relative to the motor winding's rated voltage, the lower the required power supply current.

▪ No-Load Current

In open-loop mode, without pulse input, the driver board will automatically enter idle current after 500ms to reduce the motor heat. When pulses are input, the current will return to the set value.

▪ Regenerative Current

When the motor slows down, it acts like a generator, converting the load's kinetic energy into electrical energy. Some energy is absorbed by the driver board and the motor. In applications with large loads running at high speeds, significant kinetic energy may be converted into electrical energy. Typically, simple linear power supplies use a large capacitor to absorb this energy without damaging the system. However, switching power supplies tend to shut down under over-voltage conditions,

and the excess energy will be fed back into the driver board, which may trigger an over-voltage alarm and potentially damage the driver board.

• Input Port

- Sourcing or sink digital input

Feature	Details
Standard	Isolated PLC source
Input current	8mA max
High-level input voltage sourcing mode	$4V < V_{in} < 24V$
Low-level input voltage sourcing mode	$0V < V_{in} < 0.8V$
Universal signal input frequency	1KHz (50% duty cycle)
Input signal common	Common negative and common positive compatible

Any soft configuration is required to switch sourcing or sinking mode.

a) Sinking input diagram example

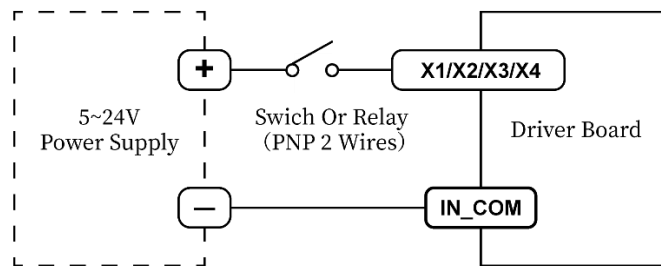

b) Sourcing input diagram example

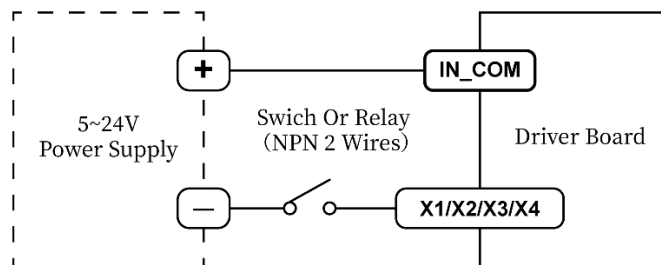

- Analog input

Feature	Details
Minimum input voltage	0V
Maximal input voltage	10 V

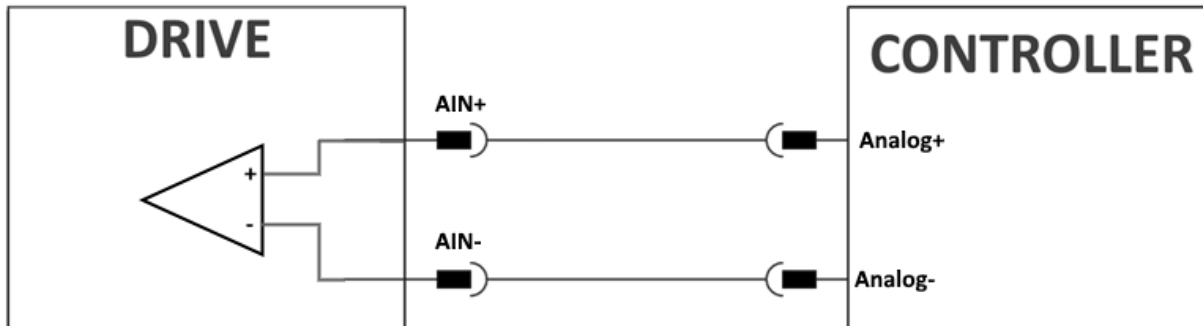

- High-speed Input Port

The driver board has two high-speed pulse input ports (PUL, DIR), which can be configured for pulse and direction signals.

Feature	Details
Standard	Optocoupler isolated signal
Voltage compatibility	5-24 V
Signal input frequency	200KHz (50% duty cycle)
Minimum signal width	2.5 μ s

- Pulse Signal: PULSE

The driver board port is equipped with an optocoupler and can accept 5~24VDC single-ended or differential signals. A change from off to on is interpreted as a valid pulse command. For a common anode configuration, a low level is valid, and the driver board will drive the motor one step according to the corresponding timing. For proper operation, the effective level signal's duty cycle should be below 50%. To ensure reliable response to the pulse signal, the duration of the valid pulse signal level should be no less than 2.5 μ s. The driver board's signal response frequency is 200kHz, and excessively high input frequencies may lead to incorrect responses.

- Direction Signal: DIR

The board can accept 5~24VDC single-ended or differential signals. The internal optocoupler's on/off state is interpreted as the two directions of motor rotation, and changing the direction signal will change the motor's rotation direction. The floating input is interpreted as a high level. It is

important that the direction signal is established at least $10\mu\text{s}$ before the pulse signal input, to avoid incorrect responses from the driver board. When changing motor direction, make sure the motor decelerates to a stop before switching direction at the start frequency. The direction signal should be changed after the last pulse of the previous direction and before the first pulse of the new direction. When direction change is not needed, the direction signal input can be left floating.

- Pulse/Direction Input Timing Diagram

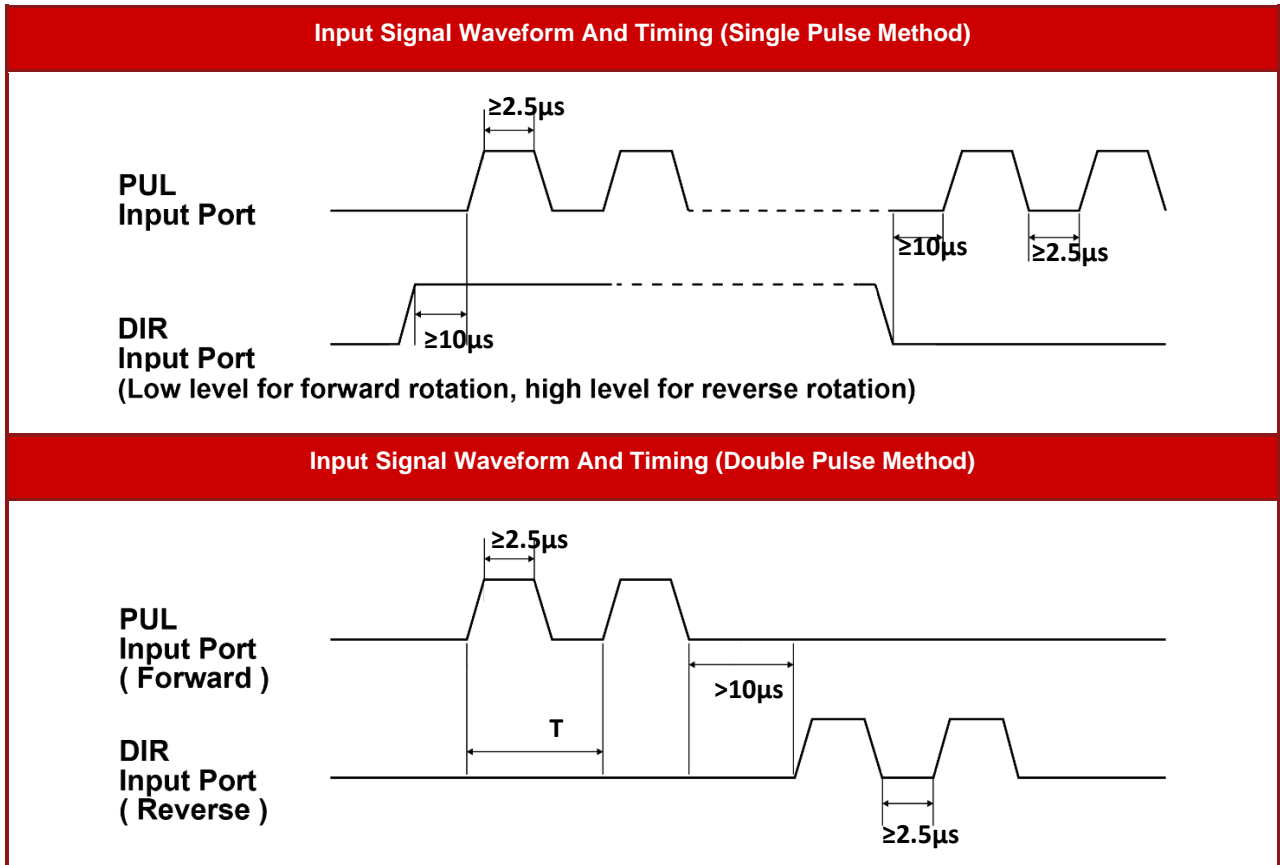

• Output Port

- Sourcing or Sinkink digital output

Feature	Details
Standard	Optically isolated PLC sink
Supply output (VDD)	30V max
Max output current	50 mA
Collector emitter saturation voltage	0.2V
Output signal common	common negative and common positive compatible

Any soft configuration is required to switch sourcing or sinking mode.

a) Sinking output diagram example

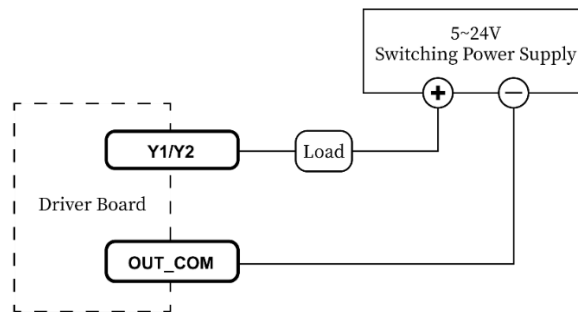

b) Sourcing output diagram example

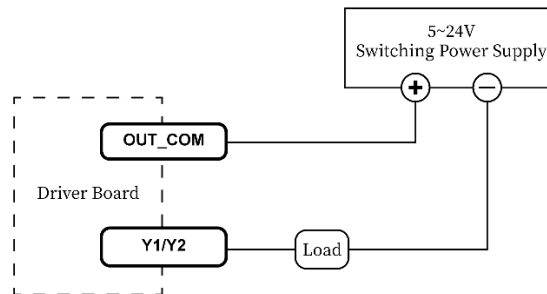

• Wiring Requirements

- **Please connect the power supply correctly, pay attention to the polarity of the power supply, and make sure that the motor and power connector are correct before powering up!**
- All thread colors mentioned in this article are general, please refer to the real thing!
- When stripping wires, do not put a layer of solder on the wire first, which may prevent proper wiring.
- When wiring, be careful not to kink the core wires, and the core wires must not leak out so as to avoid short-circuiting the wires.
- Please connect the core wires directly, do not solder. Otherwise, sometimes the wire will be broken due to vibration.
- It is strictly prohibited to tin the wire head and connect it to the terminal, otherwise the terminal may be damaged by overheating due to high contact resistance.
- Wiring leads should not be exposed outside the terminals to prevent accidental short-circuiting and damage to the driver board.
- It is strictly prohibited to unplug the strong electric (motor and power) terminals of the drive board with electricity, when the motor stops with electricity, there is still a large current flowing through the coil, and unplugging the strong electric (motor and power) terminals will result in a huge instantaneous induced electromotive force that will burn out the drive board.
- Tighten the terminals with a special tool.
- No pressure should be applied to the wires after wiring.
- In order to prevent interference with the driver board, it is recommended that the control signals use shielded cable lines, and the shield is shorted to ground, in addition to special requirements, the shield of the control signal cable is grounded at one end: one end of the shielded line of the host computer is grounded, and one end of the shielded line of the driver board is suspended. The same machine is only allowed to be grounded at the same point, if it is not a real grounding line, may interfere with the seriousness of the shield layer is not connected at this time.
- If a power supply feeds multiple driver boards, parallel connections should be taken at the power supply, chaining to one and then the other is not allowed.

5. Dimensions

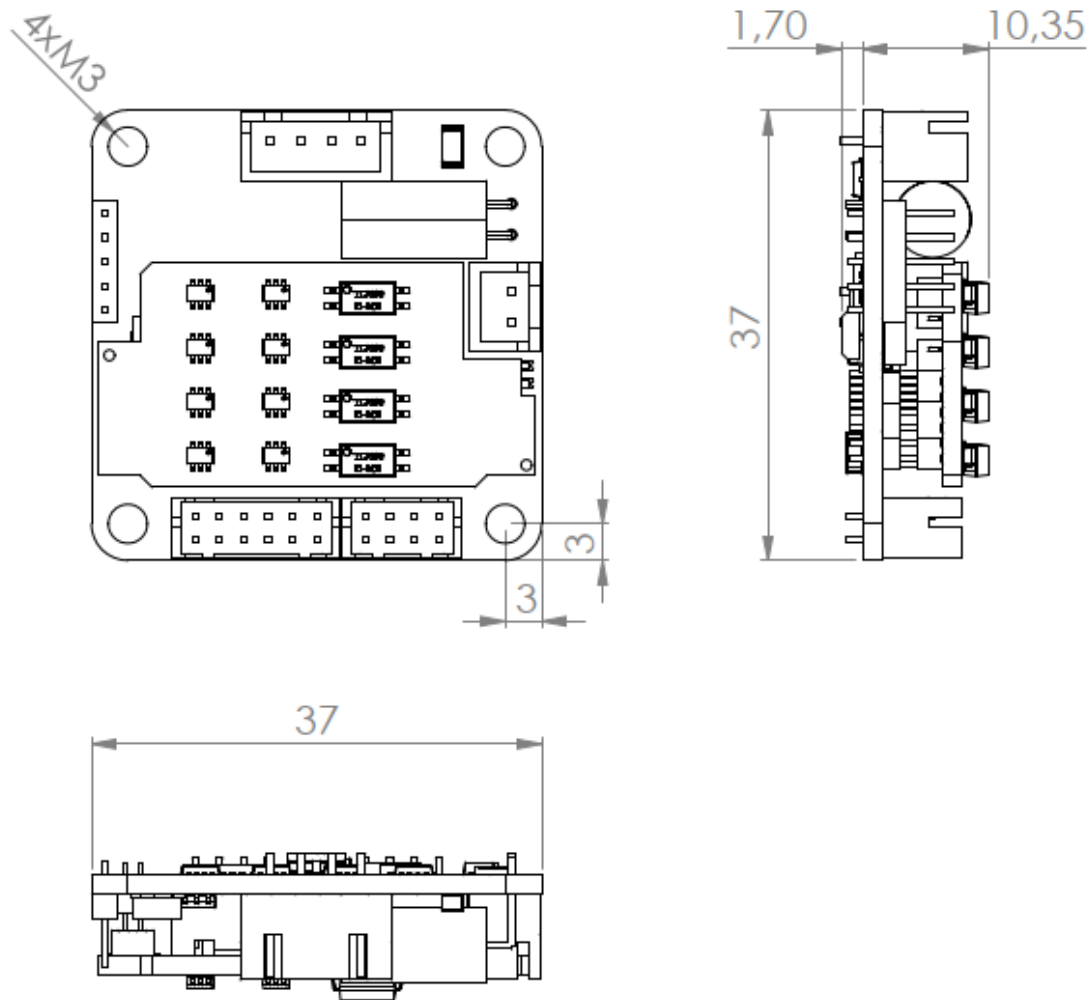

6. Supplemental directives

• Copyright

A2V Mécatronique owns the content of this user manual in its entirety, including but not limited to pictures, logos, trademarks, and resources.

Redistribution of sources or derived formats (for example, Portable Document Format or Hypertext Markup Language) must retain the above copyright notice, and the complete data sheet, user manual, and documentation of this product including associated application notes; and a reference to other available product-related documentation.

• Trademark Designations and Symbols

Trademark designations and symbols used in this documentation indicate that a product or feature is owned and registered as trademark and/or patent either by A2V Mécatronique or by other manufacturers, whose products are used or referred to in combination with A2V Mécatronique products and A2V Mécatronique product documentation.

This user manual is a non-commercial publication that seeks to provide concise scientific and technical user information to the target user. Thus, trademark designations and symbols are only entered in the Short Spec of this document that introduces the product at a quick glance. The trademark designation /symbol is also entered when the product or feature name occurs for the first time in the document. All trademarks and brand names used are property of their respective owners.

• Target user

The documentation provided here, is for programmers and engineers only, who are equipped with the necessary skills and have been trained to work with this type of product.

The Target User knows how to responsibly make use of this product without causing harm to himself or others, and without causing damage to systems or devices, in which the user incorporates the product.

• Disclaimer: Life Support Systems

A2V Mécatronique does not authorize or warrant any of its products for use in life support systems, without the specific written consent of A2V Mécatronique.

Life support systems are equipment intended to support or sustain life, and whose failure to perform, when properly used in accordance with instructions provided, can be reasonably expected to result in personal injury or death.

Information given in this document is believed to be accurate and reliable. However, no responsibility is assumed for the consequences of its use nor for any infringement of patents or other rights of third parties which may result from its use. Specifications are subject to change without notice.

• **Disclaimer: Intended Use**

The data specified in this user manual is intended solely for the purpose of product description. No representations or warranties, either express or implied, of merchantability, fitness for a particular purpose or of any other nature are made hereunder with respect to information/specification or the products to which information refers and no guarantee with respect to compliance to the intended use is given.

In particular, this also applies to the stated possible applications or areas of applications of the product. A2V Mécatronique products are not designed for and must not be used in connection with any applications where the failure of such products would reasonably be expected to result in significant personal injury or death (safety-Critical Applications) without A2V Mécatronique consent.

A2V Mécatronique products are not designed nor intended for use in military or aerospace applications or environments or in automotive applications unless specifically designated for such use by A2V Mécatronique. A2V Mécatronique conveys no patent, copyright, mask work right or other trade mark right to this product. A2V Mécatronique assumes no liability for any patent and/or other trade mark rights of a third party resulting from processing or handling of the product and/or any other use of the product.